



**Aeration  
Industries®**

## **Argos™ SBR** (Sequencing Batch Reactor)

### **A Compact SBR System Offering Process Flexibility and Major Capital Savings**

The Argos SBR offers the same design benefits of traditional SBR systems for municipal and industrial wastewater treatment with improved design features including a uniquely engineered four-sided gear-driven decanter and advanced surface mounted aeration/mixing equipment. The new system results in substantial capital investment savings, operational savings, and improved process flexibility.

The Aire-O<sub>2</sub> Triton® provides all of the aeration and mixing in the Argos SBR. As a result, the SBR design is greatly simplified and costs are dramatically reduced. The capital expense of a blower building, blowers, and piping networks associated with diffused air systems are totally eliminated. The Triton units are float mounted and ride up and down on slide poles to accommodate the changing water levels in the SBR insuring easy operation and maintenance. In addition, the Triton's ability to mix only or to simultaneously aerate and mix by simply turning the unit's blower on and off allows for a high degree of process flexibility and easy integration and control of biological nutrient removal (BNR) cycles.

### **Argos™ SBR Benefits:**

- The Triton aerator/mixers eliminate diffusers and associated air piping networks, mixers, blowers, blower buildings, and enclosures.
- The Triton's ability to operate in either the 'mixing + aeration' or 'mixing only' mode by simply cycling the unit's blower on and off allows for better process control and flexibility, making it very easy to integrate nitrification/ denitrification cycles and to facilitate biological phosphorus removal.
- Gear-driven four-sided stainless steel decanter with solids exclusion weir insures a controlled high quality effluent.
- Tested and proven controls package.
- Mixing and aeration equipment is surface mounted allowing for ease of inspection and maintenance.
- Powerful vertical and horizontal mixing provided by the Triton units allows for deep basin designs reducing plant footprint.
- Multi-reactor Batch and Single-reactor Continuous Flow designs available.
- Aire-O<sub>2</sub> Triton units come with standard 3-year mechanical warranty.



*Triton  
aerator/mixer  
on slide  
rail system  
is easy to  
install and  
maintain.*



*The Wagner  
Fluid Systems  
four-sided  
controlled  
decanter  
insures  
a high  
quality  
effluent.*

# Argos™ SBR

## Typical Argos™ SBR Operation

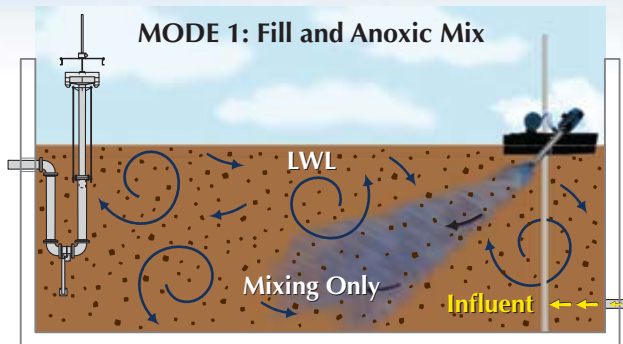

- Influent entering SBR.
- Water level RISING from low water level (LWL) for set time.
- Triton blower is OFF, Triton mixer motor is ON.
- Decanter raised above maximum water level.
- Note: If the process does not need an anoxic mix, this will be an aerobic mix (see mode 2).

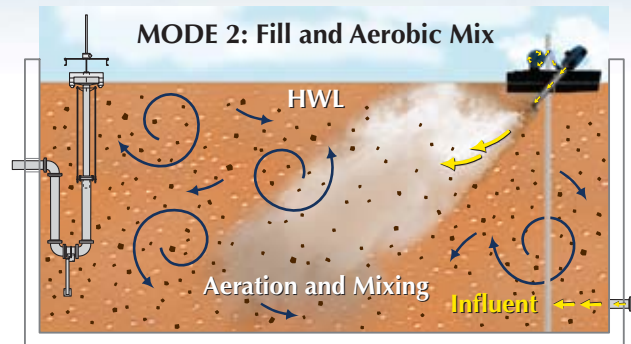

- Influent entering SBR until HWL reached and then, influent stops.
- Aeration and mixing continuing for a set time.
- Triton blower and mixer are ON.

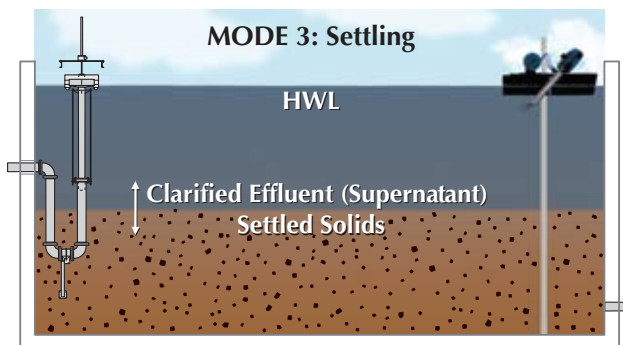

- No influent.
- No aeration/mixing (Triton OFF).
- Mixed liquor suspended solids (MLSS) allowed to settle out.

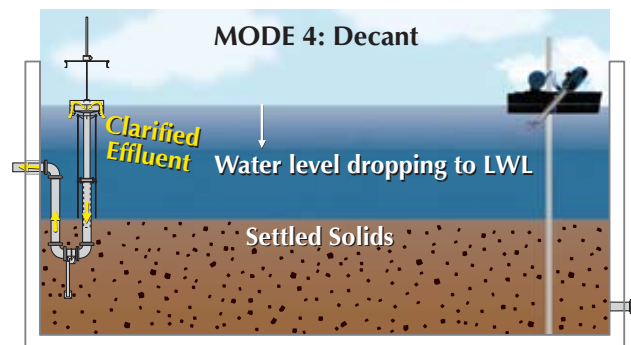

- No influent.
- No aeration/mixing (Triton OFF).
- Decanter is slowly lowered to remove the clarified effluent.

## Typical Argos™ SBR Layout

MODES 1 thru 4 occur in basins #1 and #2.

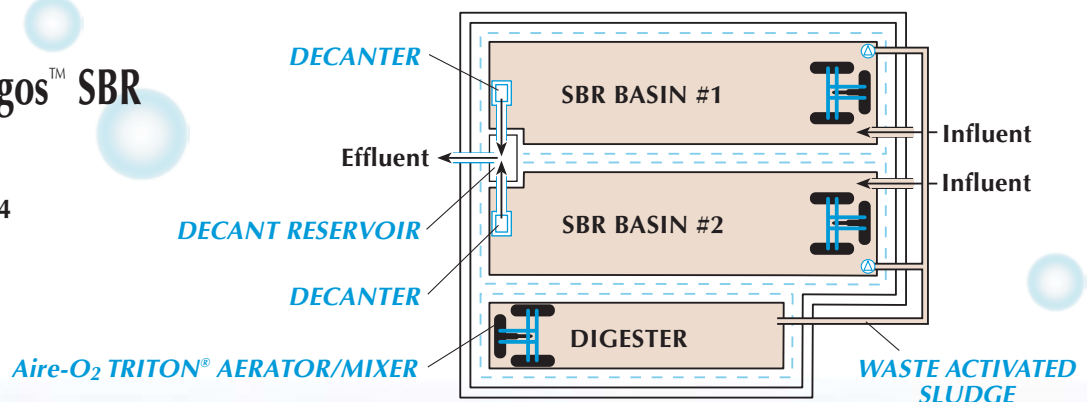

**Aeration Industries**

Aeration Industries International, Inc.  
 Mail To: P.O. Box 59144 • Minneapolis, MN 55459-0144 USA  
 Ship To: 4100 Peavey Road • Chaska, MN 55318-2353 USA  
 +1-952-448-6789 / 1-800-328-8287 (USA) / FAX +1-952-448-7293  
[www.aireo2.com](http://www.aireo2.com)