



**Aeration
Industries®**

AIRE-O₂® 275 Aerator

Same Powerful AIRE-O₂® Performance for the Economy-Minded Customer

The same essential design features and advantages delivered by the original AIRE-O₂® aspirator aerator are also available in our smaller units with heavy-duty industrial motors ranging from 2 through 7.5 Hp (1.5 - 5.5 kW). The AIRE-O₂® 275 Aerator is available in three different types of float-mounted systems.

Aeration Industries International introduced the innovative, patented aspirator aeration technology in 1974. The AIRE-O₂® aerator is a high quality, minimal maintenance aspirator with superior performance and a proven track record. More than 65,000 aerators have been installed throughout the U.S. and over 92 countries worldwide.

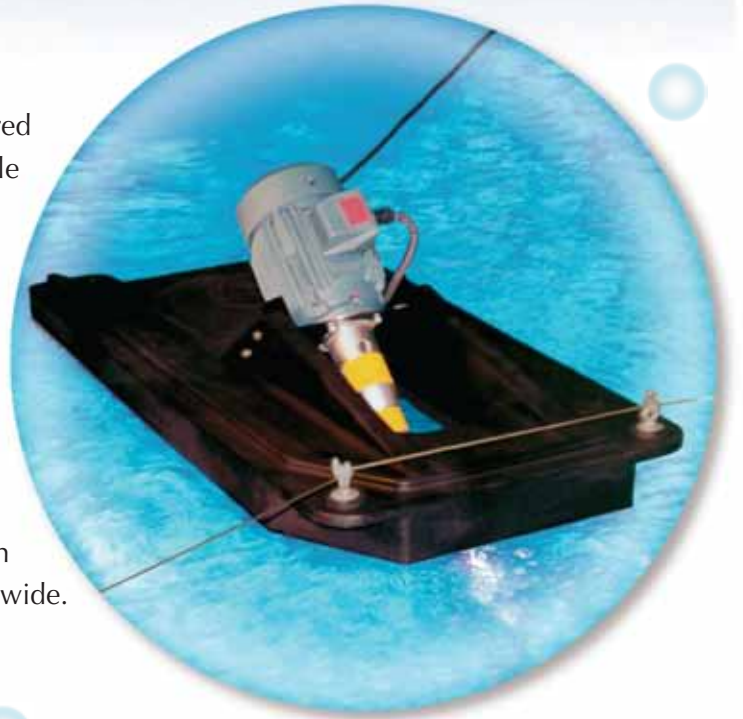

AIRE-O₂® 275 Aerator Benefits:

- Re-engineered with the highest quality materials.
- Increased mixing and oxygen dispersion.
- Ease of installation and portability.
- Same engineering integrity as AIRE-O₂® Aspirator aerator at a reduced price.
- Minimal maintenance.
- No aerosols or odors, “community friendly”
- Ideal for retrofits and upgrades
- Three (3) Year Warranty.

Available in 2-7.5 Hp (1.5-5.5 kW) sizes in worldwide voltage, phase, Hz combinations.



The AIRE-O₂® 275 aerator, mounted on a uni-float above, creates no aerosols or odors and is quiet in operation due to its sub-surface operation.



An underwater view of the AIRE-O₂® 275 aerator's mixing capabilities

AIRE-O₂[®] 275 Aerator

Pontoon System*

*Tri-Float not illustrated.

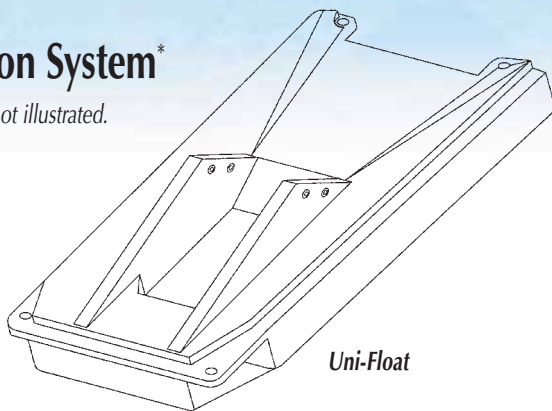

Uni-Float

Not drawn to scale,
for illustration
purposes only.

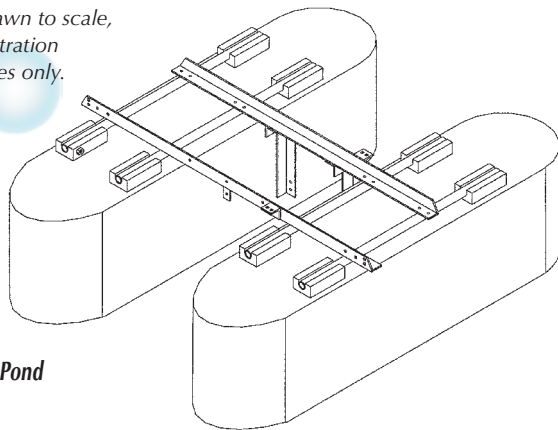

Intra-Pond



The 275 aerator provides years of dependable service.
The unit, pictured above, is mounted on an intra-pond float.

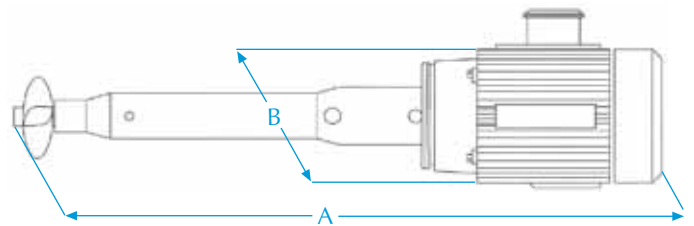

60 / 50 Hz Weights & Measures for the AIRE-O₂[®] 275 Aerator:

NEMA AND IEC Motors Available

HP	kw	Dimensions		Motor Frame Size	60 hz Motor RPM	Motor FLA@ 460V	50 hz Motor RPM	Motor FLA@ 380V	Ship weight Intra-Pond lbs. (kg)	Ship weight Tri-Float lbs. (kg)	Pontoon System Avail.
		A In. (m)	B In. (m)								
2	1.5	45 (1.14)	14 (.35)	180TC	3505	3.6	2945	6.3	329 (149)	404 (183)	c
3	2.2	45 (1.14)	14 (.35)	184TC	3505	4.6	2900	5.2	331 (150)	406 (184)	c
5	4	45 (1.14)	14 (.35)	184TC	3480	7.8	2890	8.6	333 (151)	408 (185)	a,b,c
7.5	5.5	45 (1.14)	14 (.35)	213TC	3505	10.2	2845	6.26	375 (170)	450 (204)	a,b,c

Data subject to change without notice.

Pontoon System

a Intra-Pond b Tri-Float c Uni-Float

Pontoon systems available for
50 hz / 60 hz may vary.
Contact factory.

FRAME SIZE, RPM, FLA, and
SHIP WEIGHTS may vary between
motor manufacturers.



**Aeration
Industries**

AIRE-O₂[®]

Aeration Industries International
Mail To: P.O. Box 59144 • Minneapolis, MN 55459-0144 USA
Ship To: 4100 Peavey Road • Chaska, MN 55318-2353 USA
+1-952-448-6789 / 1-800-328-8287 (USA) / FAX +1-952-448-7293
www.aireo2.com

© Copyright 2004, 2011 Aeration Industries International LLC. All Rights Reserved

275spec1004-02